

Engine	Cummins QSB6.7
Gross Power	164 kW (220 hp) @ 2,200 rpm
Net Power	156 kW (209 hp) @ 2,200 rpm
Operating Weight	18,450 kg
Standard Bucket Size	3 m ³
Standard Breakout Force	162 kN
Standard Dump Clearance	3,100 mm

856III WHEEL LOADER

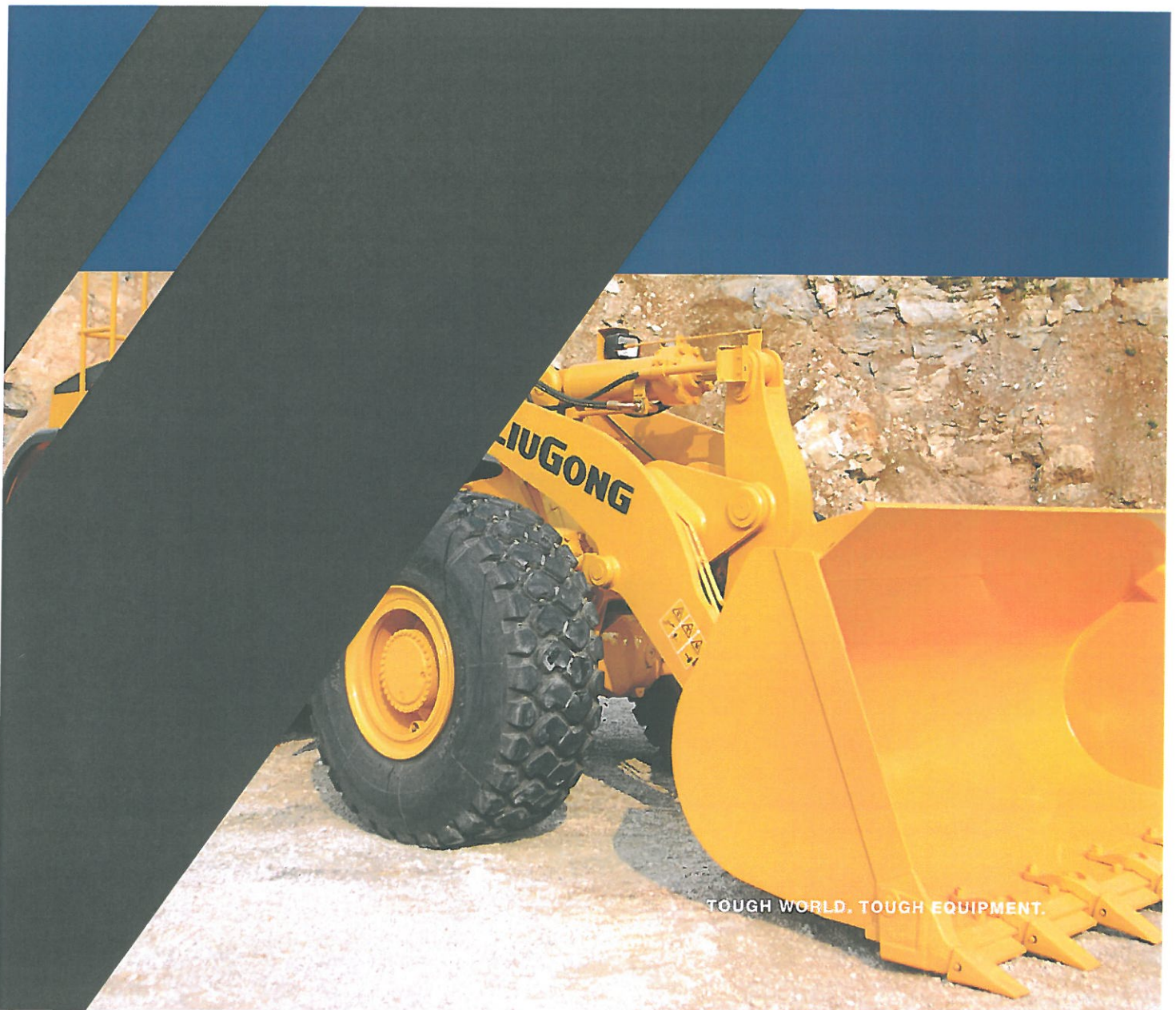

TOUGH WORLD. TOUGH EQUIPMENT.

856III SPECIFICATIONS >>>

ENGINE

Emission Regulation	Tier 3 / Stage IIIA
Make	Cummins
Model	QSB6.7
Gross Power	164 kW (220 hp) @ 2,200 rpm
Net Power	156 kW (209 hp) @ 2,200 rpm
Peak Torque	949 N · m @ 1,500 rpm
Displacement	6.7 L
Number of Cylinders	6
Aspiration	Turbocharged & Air-to-air intercooled

TRANSMISSION

Transmission Type	Countershaft, power shift
Torque Converter	Single stage, three elements
Maximum Travel Speed, fwd	38 km/h
Maximum Travel Speed, rev	24 km/h
Number of Speeds, fwd	4
Number of Speeds, rev	3

AXLES

Differential Front Type	Limited slip
Differential Rear Type	Limited slip
Axle Oscillation	±11°

STEERING

Steering Configuration	Articulated
Steering Relief Pressure	16 MPa

BRAKES

Service Brake Type	Wet disc brake
Service Brake Actuation	Hydraulic
Parking Brake Type	Manual electronic control
Parking Brake Actuation	Hydraulic

HYDRAULIC SYSTEM

Main Pump Type	Vane
Main Relief Pressure	20 MPa
Raise	6.1 s
Dump Time	1.3 s
Float Down Time	3.5 s
Fastest Total Cycle Time	10.9 s

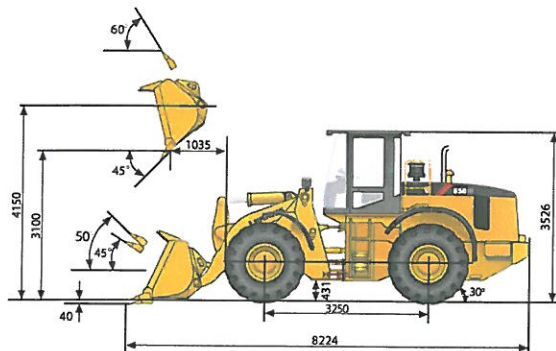

LOADER ARM PERFORMANCE

Tipping Load - Straight	15,148 kg
Tipping Load - Full Turn	13,330 kg
Bucket Breakout Force	162 kN
Maximum Dump Angle at Full Height	45°
Dump Clearance at Full Height Discharge	3,100 mm
Dump Reach at Full Height Discharge	1,035 mm
Maximum Hinge Pin Height	4,150 mm
Maximum Digging Depth, Bucket Level	40 mm
Bucket Rollback at Ground Level	45°
Bucket Rollback at Carry	50°
Bucket Rollback at Maximum Height	60°

BUCKET PERFORMANCE

Reference Bucket	3 m ³
------------------	------------------

DIMENSIONS

Length with Bucket Down	8,224 mm
Width Over Tires	2,750 mm
Wheelbase	3,250 mm
Wheel Tread	2,150 mm
Ground Clearance	431 mm
Turn Angle, Either Side	38°
Rear Angle of Departure	30°
Turning Radius, Outside of Tire	6,094 mm
Turning Radius, Center of Tire	5,794 mm
Turning Radius, Bucket Carry	6,912 mm

TIRES

Tire Size	23.5 R 25
-----------	-----------

OPERATING WEIGHTS

Operating Weight	18,450 kg
------------------	-----------

SERVICE CAPACITY

Fuel Tank	310 L
Engine Oil	16 L
Cooling System	36 L
Hydraulic Reservoir	245 L
Transmission and Torque Converter	40 L
Axles, each	34 L

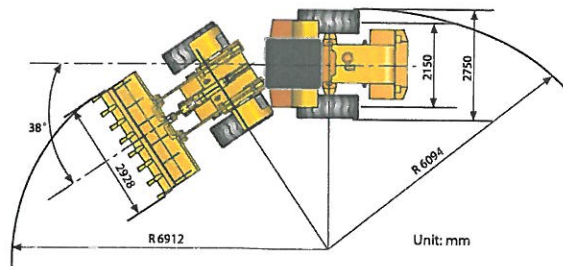

Guangxi Liugong Machinery Co., Ltd.

No. 1 Lutai Road, Liuzhou, Guangxi 545007, PR China
T: +86 772 3886124 E: overseas@liugong.com
www.liugong.com

Specifications and designs are subject to change without notice. Machines shown may include optional equipment.

05/2014 Designed by LiuGong