

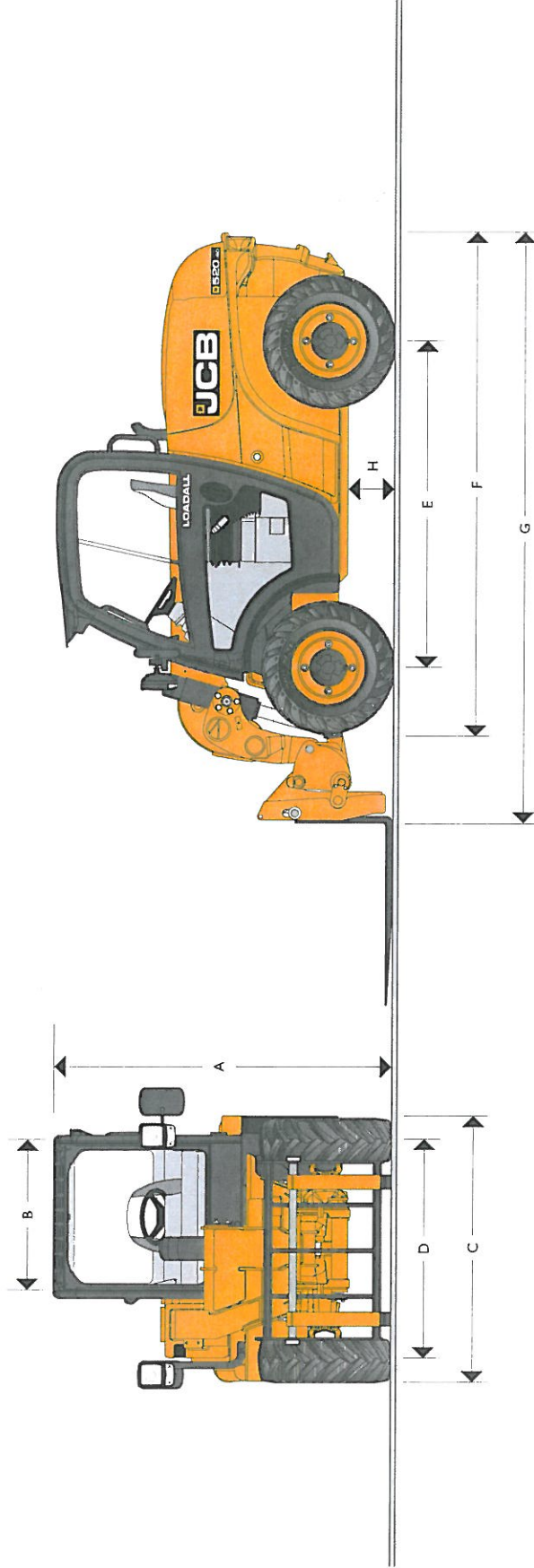

MAX. PAYLOAD: 2.0 tonnes (4409lb) MAX. LIFT HEIGHT: 4 metres (13ft 1in) MAX. HORSEPOWER: 37.5 kW (50hp)



STATIC DIMENSIONS

Machine model	520-40	Machine model	520-40
A Overall height:	1.97 (6-6) m (ft-in)	H Ground clearance	0.27 (0-11) m (ft-in)
B Inside width of cab	0.92 (3-0)	Outer turn radius over tyres	3.05 (10-0)
C Width over tyres (min)	1.56 (5-1)	Weight	4400 (9700) kg (lb)
D Front track	1.29 (4-3)	Tyres	10x16.5 12 ply 12x16.5 10 ply
E Wheel base	1.90 (6-3)		
F Overall length to front of tyres	2.92 (9-6)		
G Overall length to front of carriage	3.38 (11-1)		



LIFT PERFORMANCE

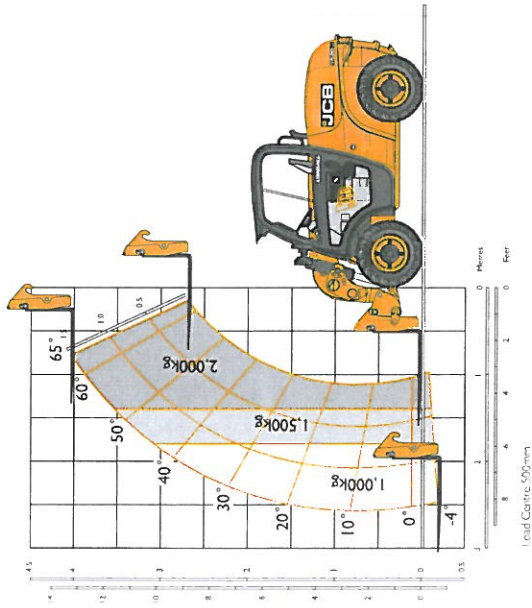

LIFT PERFORMANCE

Machine Model	Compact Tool Carrier	Skid Steer Tool Carrier
	520-40	520-40
Lift capacity at full height	2000 (4408) kg (lb)	2000 (4408) kg (lb)
Lift capacity at full reach	1000 (2204) kg (lb)	1000 (2204) kg (lb)
Max. lift height	4035 (13-3) mm (ft-in)	4035 (13-2) mm (ft-in)
Reach at max. lift height	890 (2-11) mm (ft-in)	815 (2-8) mm (ft-in)
Maximum reach forward	2590 (8-6) mm (ft-in)	2515 (8-4) mm (ft-in)

LOADER PERFORMANCE

Machine Model	Compact Tool Carrier	Skid Steer Tool Carrier
	520-40	520-40
Shovel rated capacity	0.7 m ³	0.5 m ³
Breakout force	36 (3700) kN (kg)	33 (3390) kN (kg)
	3700 (8157) kg (lb)	3400 (7495) kg (lb)
Dump height (max)	3555 (11-8) mm (ft-in)	3500 (11-7) mm (ft-in)
Dump angle at max height	33 degrees	40 degrees
Loadover height (max)	4015 (13-1) mm (ft-in)	4015 (13-1) mm (ft-in)
Rollback angle at ground	38 degrees	31 degrees
Carriage rotation angle (total)	140 degrees	140 degrees
Bucket width	1750 (5-8) mm (ft-in)	1730 (5-7) mm (ft-in)



ENGINE

Model	520-40
Displacement	Perkins Diesel 104D-22 litres
Fuel	Diesel
Cooling	Liquid
Bore	84
Stroke	100
Gross power @ 2800 rpm	
ISO 14396	37.5 (50)
Gross torque @ 1300 rpm	
ISO 14396	143 (105.47)
Emission certification	EC Stage II(A/USA EPA Tier 3
Engine oil service intervals	500 hours

TRANSMISSION

Hydrostatic transmission.

Closed loop variable displacement piston pump and 2 speed bent axis motor.

Transmission inching facility on operation of a combined inching and braking pedal.

Front and rear drive axles: Epicyclic hub reduction type with mid mounted drop box. Permanent 4WS and 4WD.

- Rear axle oscillation
- Optional front and rear limited slip diff axles.
- Travel speed 20kph

BRAKES

Service brake: Hydraulically actuated, disc brake on the transmission output shaft.

Parking brake: Manually operated disc brake on the transmission output shaft.

BOOM AND CARRIAGE

Boom is manufactured from high tensile steel.

Low maintenance, hard wearing pads.

JCB tool carrier parallel lift carriage with manual or hydraulic pin locking, accepts forklift frame with integral pallet forks and a wide range of attachments.

Compact Tool Carrier: Compact Loadall compatibility.

Skid Steer Tool Carrier: Skid steer universal compatibility hitch.

SERVICE CAPACITIES

	litres (UK gal)
Fuel tank	61 (13.4)
Hydraulic tank	33 (7.3)
Coolant	8 (1.8)

ELECTRICS

12 V negative earth, 75 AH heavy duty battery, 65 amp alternator. Full road lighting, directive indicators, hazard warning.

HYDRAULICS

Machine model	520-40
Operating system pressure	bar (psi)
Flow at system pressure (@ 2800rpm)	litre/min
Cycle times	seconds
Boom raise	5.8
Boom lower	4
Extend	5.7
Retract	4
Bucket dump	3.7
Bucket crowd	3.2

SAFETY CHECK VALVES

Fitted to crowd, extension and lift rams.

CAB

Quiet, safe and comfortable cab conforms to ROPS ISO3471 and FOPS ISO 3449. Tinted glass all round with laminated front and roof screen. Front, rear screen wiper and heater/screen demister. Opening door window. Visual warning system for coolant temperature, engine oil pressure, air cleaner, battery charge, transmission oil pressure, engine temperature, fuel gauge and hourmeter.

Boom control lever incorporating forward/reverse switch. Throttle and brake pedals floor mounted. Adjustable deluxe suspension seat with side mounted park brake lever. Automatic eye level audio-visual load moment indicator/warning system receiving a signal from a load sensor on the rear axle.

This system continuously monitors the machine's forward stability and leaves the operator in control at all times.

STEERING

Full power-hydrostatic steering. Permanent 4WS with 32° lock front and rear axles provides exceptional manoeuvrability.

OPTIONS AND ACCESSORIES

Options: Work lights, rotating flashing beacon, fire extinguisher, limited slip diff front and rear axles, screen guard, sun blind, mechanical or hydraulic Compact tool carrier and Skid Steer tool carrier, battery isolator.

Attachments: Contact your local dealer for details of the comprehensive range.



A GLOBAL COMMITMENT TO QUALITY

JCB's total commitment to its products and customers has helped it grow from a one-man business into Britain's largest privately owned manufacturer of backhoe loaders, crawler excavators, wheeled excavators, telescopic handlers, wheeled loaders, dump trucks, rough terrain fork lifts, industrial fork lifts, mini/midi excavators, skid steer loaders, tractors and compaction equipment.

By making constant and massive investments in the latest production technology, the JCB factories have become some of the most advanced in the world.

By leading the field in innovative research and design, extensive testing and stringent quality control, JCB machines have become renowned all over the world for performance, value and reliability.

And with a global sales and service network of more than 650 dealers and agents, we aim to deliver the best customer support in the industry.

Through setting the standards by which others are judged, JCB has become one of the world's most impressive success stories.



JCB Sales Limited, Rokester, Staffordshire ST14 5JP. Tel: 01889 590312. Fax: 01889 590588. Web: <http://www.jcb.com>

JCB reserves the right to change specifications without notice. Illustrations shown may include optional equipment and accessories. The JCB logo is a registered trademark of J.C. Bamford Excavators Ltd.

